

# 613

55 Cedar Pointe Drive

Barrie, ON

**BASIC RENT**  
\$16.50

**ADDITIONAL RENT**  
\$11.65

**GROSS COST PER SF**  
\$28.15

**COST PER MONTH**  
\$4,023.10

## SUITE DETAILS

**MIN DIVISIBLE**  
No

**MAX CONTIGUOUS**  
1,715 SF

**UNIT TYPE**  
Office, Retail

**SQUARE FEET**  
1,715 SF

**FLOOR**  
1

**AVAILABILITY**  
Immediate

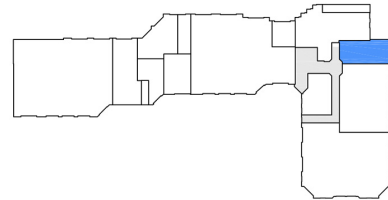

KEY PLAN

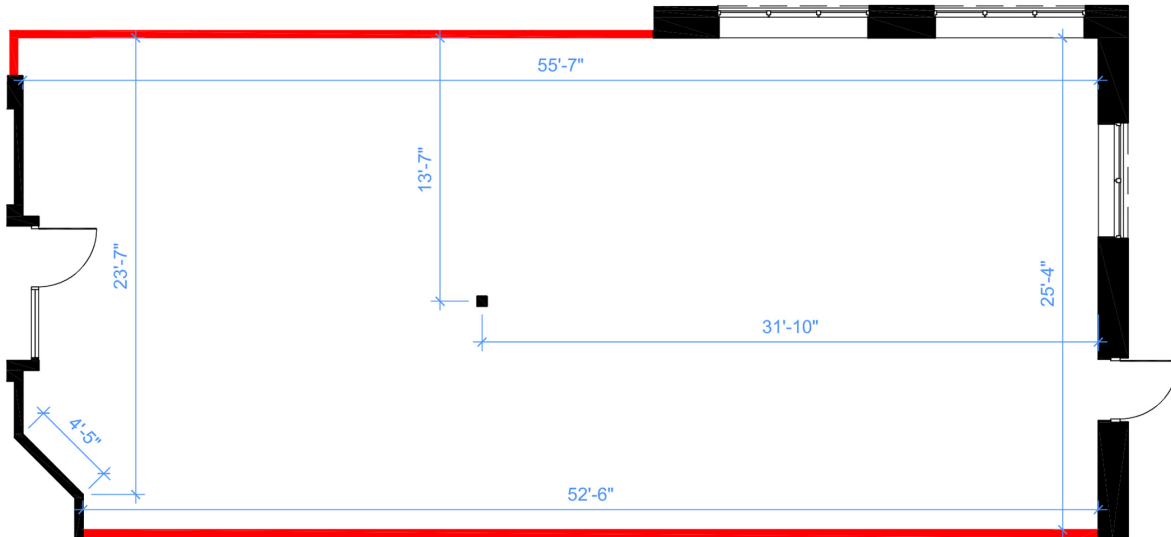

— DEMISING WALL

